

Separable straight connector (Interface A / 250 A)

formfit®

for polymeric cables - Deadbreak operation
 Generally meets the requirements of HD 629-1 S2 - IEC 60502-4.
 Interfaces: CENELEC EN50180 - EN50181.



Medium Voltage (MV)
Up to 12,7/22 (24) kV
MV Separable Connectors rating 250 A (Interface A)
Reference: FMCS-250

Product Application and Design

Utilisation

- For connection of polymeric MV cables to transformers, switchgear units, motors, etc...
- Indoor and outdoor installation. The connector is entirely protected by a watertight conductive envelope connected to earth.
- Continuous 250 A rms.
 overload 300 A rms (8 hours per 24-hour period).
- Deadbreak operation. Voltage detection through an integrated capacitive voltage divider.

Cable

- Single core polymeric insulation (XLPE...)
- Copper or aluminium conductors.
- Semi-conducting screen either extruded or taped.
- Metallic screen of copper tape, copper wires or polylam type.
- Insulation voltage up to 12,7/22 (24) kV.
- Conductor sizes: 16 mm² to 95 mm² (or 120) mm².

Packing

Supplied as a kit of 3 single connectors containing all the necessary components.

Shipping weight and volume (approx) of kit:
 3 kg / 0,006 m³.

Shipping weight and volume (approx): please consult us.

Other products

- Associated products such as bushing FMBOm-250, FMBOh-250 and accessories.



**INTERFACE
 A / 250 A**

Installation features

- No need for special tools, no heating, taping or filling.
- Vertical, angled or inverted position.
- No minimum distance between phases.
- Individual clamping by stainless steel brace. The three phases may also be locked together and to the equipment by use of metallic rings (supplied on request, separately or already fitted onto the moulded groove).
- Energizing may take place immediately after the connector is plugged on its mating bushing, dead-end plug...
- An unplugged connector must never be energized.

Description

- ① **Contact piece**
Crimped or indented lug with copper contact pin; designed with locking ring.*
- ② **Semi-conducting inner screen**
Insert of molded semi-conducting EPDM enclosing the metallic contact piece so that the air inside is prevented.
- ③ **Semi-conducting outer envelope (thickness 3 mm)**
Jacket made of semi-conducting EPDM. Its design provides relief of electrical stress as does a cable screen. Its connection to the cable screen ensures the assembly is maintained at earth potential.
- ④ **Insulating body**
Molded from insulating EPDM, for integral reconstitution of insulation. It maintains a uniform contact pressure on the cable insulation and on the bushing interface, providing an excellent moisture seal.
- ⑤ **Test point**
Electrically protected by a cap made of semi-conducting EPDM. A capacitive voltage divider enables to check the absence of voltage before disconnecting the connector.
- ⑥ **Locking brace**
Stainless steel brace fastening the connector onto its mating bushing or other accessories.
- ⑦ **Earthing eye**
For connection of the outer envelope to the metallic screen of the cable.
- ⑧ **Groove for locking ring**
For the fitting of a metallic ring (supplied on request) when 3-phase locking is required.
- ⑨ **Earth cover**
Molded semi-conducting EPDM. Ensures watertight protection of the earthing device.

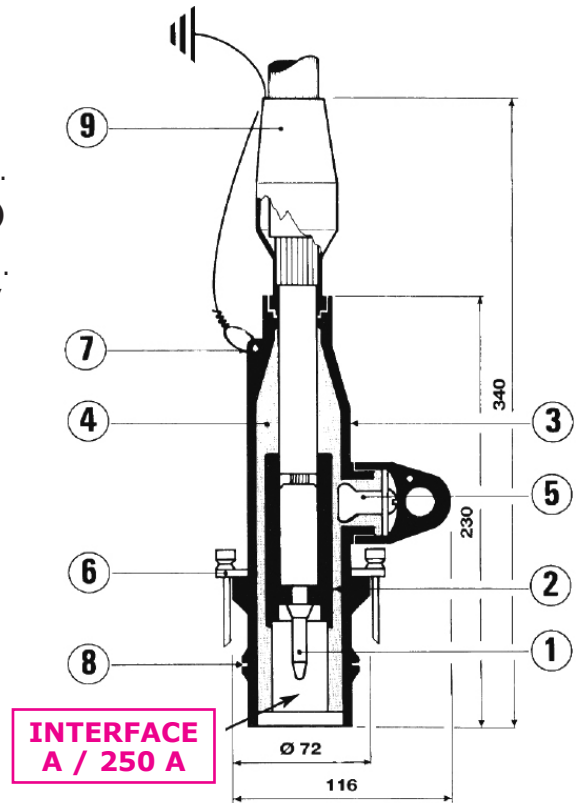

100% of the separable connectors bodies are individually tested in factory (Industrial Power Frequency and partial discharges).

* The lug depends on conductor cross section and material (copper or aluminum)

Selection guide

1- Select in the table below the kit size corresponding to the diameter over cable insulation.

Ø over insulation in mm		Kit Reference	Conductor size in mm ² (for guidance only)					
			Highest voltage in Um					
Min	Max		12 kV	17,5 kV		24 kV		
10,0	12,6	FMCS-250-A*	16					
11,8	14,5	FMCS-250-B*	25	25⁽¹⁾				
13,7	16,3	FMCS-250-C*	35	35⁽¹⁾	25	25⁽¹⁾		
15,3	17,9	FMCS-250-D*	50	50⁽¹⁾	35	35⁽¹⁾ 50⁽¹⁾	25⁽¹⁾	
17,0	19,5	FMCS-250-E*	70	95⁽¹⁾	50	70⁽¹⁾	35⁽¹⁾	
18,6	21,3	FMCS-250-F	95	120^{** (1)}	70	95⁽¹⁾	35 50⁽¹⁾	
20,2	23,0	FMCS-250-G			95	120^{** (1)}	50 70⁽¹⁾	
22,5	25,3	FMCS-250-H					70 95⁽¹⁾	
23,4	26,0	FMCS-250-J					95 120^{** (1)}	

* models with adapters ** for 120 mm², please consult us.

1- For cables with bonded outer semi-conducting layer : carefully check the diameter over insulation after removal of the outer semiconducting layer.
** available for deep indenting or hexagonal crimping. Unless otherwise stated, standard delivery will be for deep indenting. Suitable tooling to be used.

2- Specify insulation voltage in kV:
12 - 17.5 - 24

3- Select suitable earthing device in the table below:

Earthing Device Reference	Type of Metallic Screen of cable
T1	polylam
T2	Copper tape
T3	Copper wires

4- Select suitable lug:

4.1- indicate "C" for copper conductor

"A" for aluminium conductor***

4.2- indicate conducteur size in mm².

4.3- for aluminium conductor, add "DIN" if suitable.

Example of order

1 x 50 mm², 20 kV polymeric cable, diameter over insulation 21,2 mm, with copper wire screen, aluminium conductor, lug suitable for hexagonal crimping: **FMCS-250-G-24-T3-A50 DIN.**

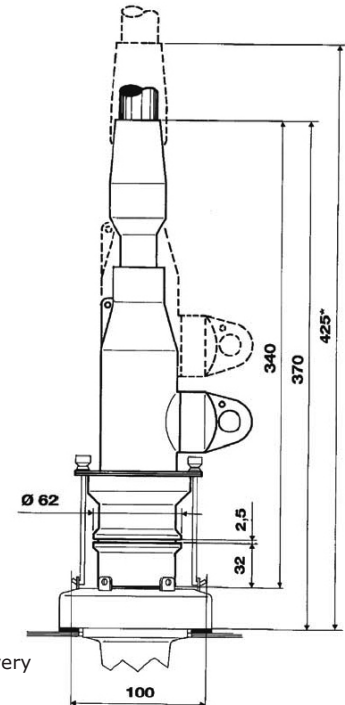

Dimension in mm

* Minimum dimension required for disconnection